

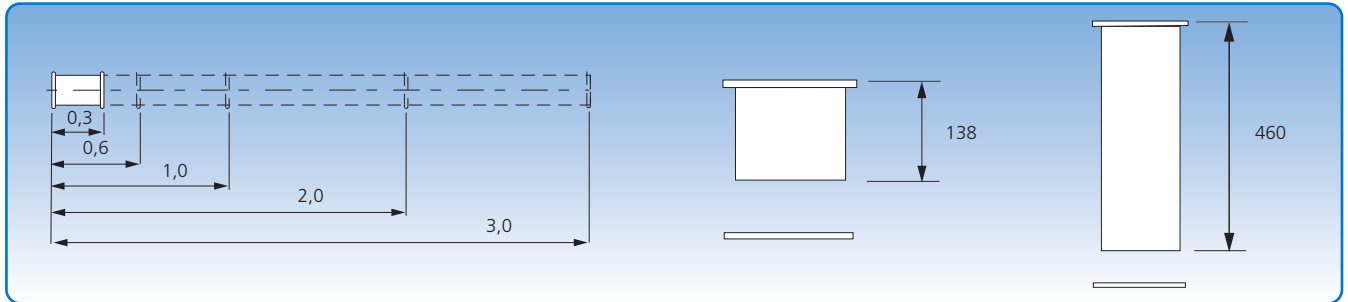

## JK-6" duct systems

Technical catalogue: Duct systems  
Section: 03  
Page: 1/2  
Revised: 01.01.2004



JK-6" duct system, galvanised

0,1 m telescopic ducts, galvanised

0,5 m telescopic ducts, galvanised

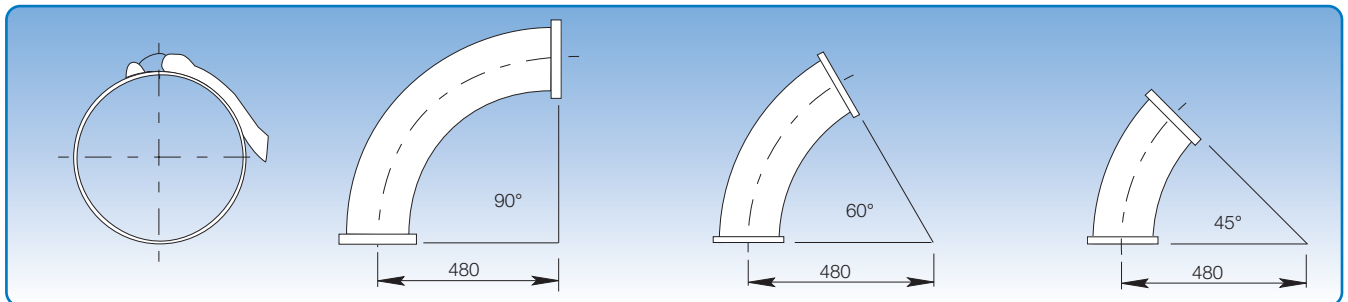

Rapid lock pull rings, galvanised

90° bends, grey

60° bends, grey

45° bends, grey

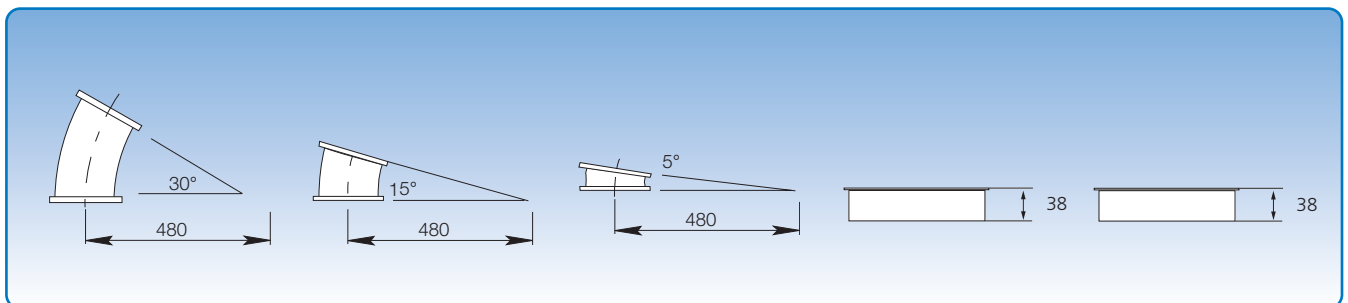

30° bends, grey

15° bends, grey

5° bends, grey

Welding ends, 1,0 mm

Welding ends, 2,0 mm

JKF's JK-6" duct system is specially designed to ensure rapid mounting with tight and smooth connections. The assembly method is rapid lock pull rings.

The special design allows for high transport capacities and gentle transport.

The rolled edges of the JK-6" system give extra strength and reduce the risk of transport damage to a minimum.



## JK-6" duct systems

Technical catalogue: Duct systems  
Section: 03  
Page: 2/2  
Revised: 01.01.2004

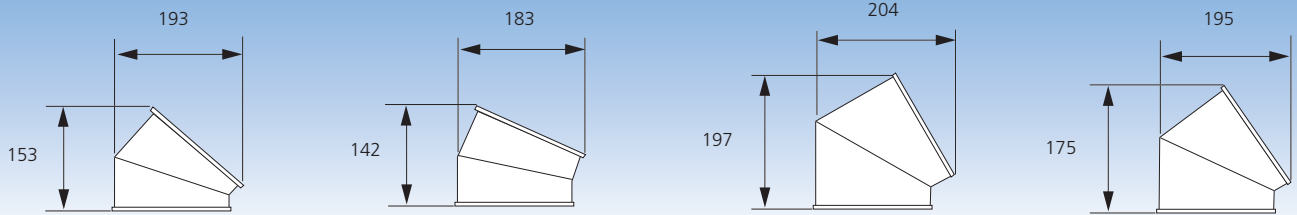

30° segment bends, 1,5 mm, grey

15° segment bends, 1,5 mm, grey

60° segment bends, 1,5 mm, grey

45° segment bends, 1,5 mm, grey

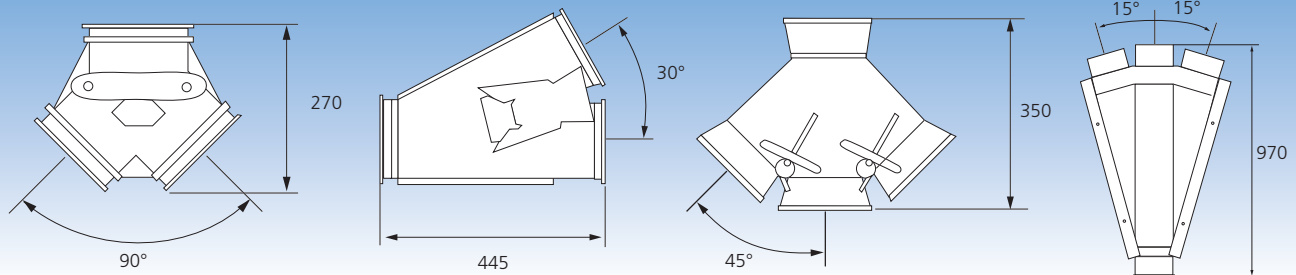

Trouser divertes, 45°, grey

Branch divertes, 30°, grey

3-way divertes, 45°, grey

3-way divertes, 15°, grey

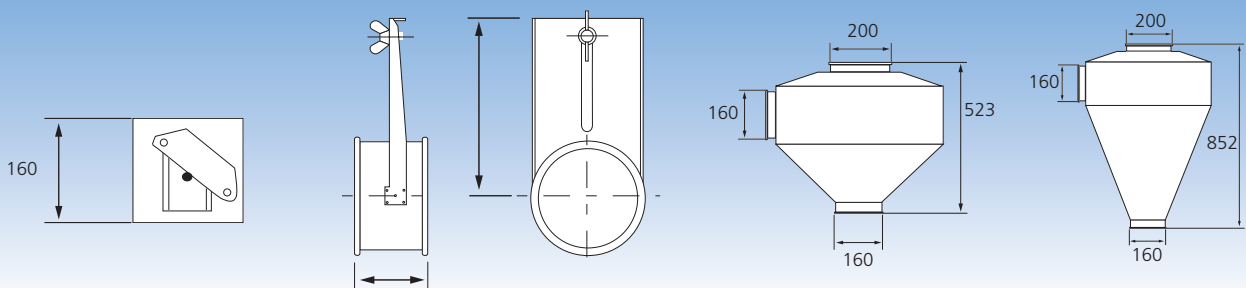

Throttle valves with spring, grey

Bulkheads, grey

Grain cyclones, galvanised

Dust cyclones, galvanised

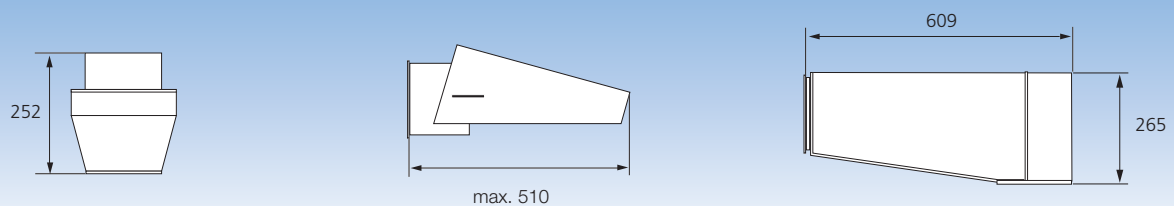

Swing outlets, grey

Outlet nozzles, blue

Exhaust heads, galvanised